Over Three Decades of Canadian Centrifuge Modelling Experience

Ryan Phillips



Western Geotechnical Centrifuge
Opening & Symposium

London, ON
May 2 & 3, 2019

Overview

The image features a map of Canada with several regions highlighted in different colors: Yukon (grey), Nunavut (light blue), Newfoundland and Labrador (orange), Manitoba (green), Saskatchewan (light green), and Ontario (yellow). Major cities are marked with stars: Whitehorse, Iqaluit, Edmonton, Regina, Victoria, Ottawa, and Toronto. A timeline at the bottom is divided into four periods: '80-'90, '90-'00, '00-'10, and '10- on. Various images are overlaid on the map, including a construction site in a snowy environment, a blue and yellow cylindrical testing rig, a large white cylindrical testing chamber, a blue and white testing rig, and a large industrial testing facility. A small inset map shows the 2005 National Building Code seismic hazard zones across Canada, with the website www.EarthquakesCanada.ca and www.tremblementsdeleer.ca listed below it.

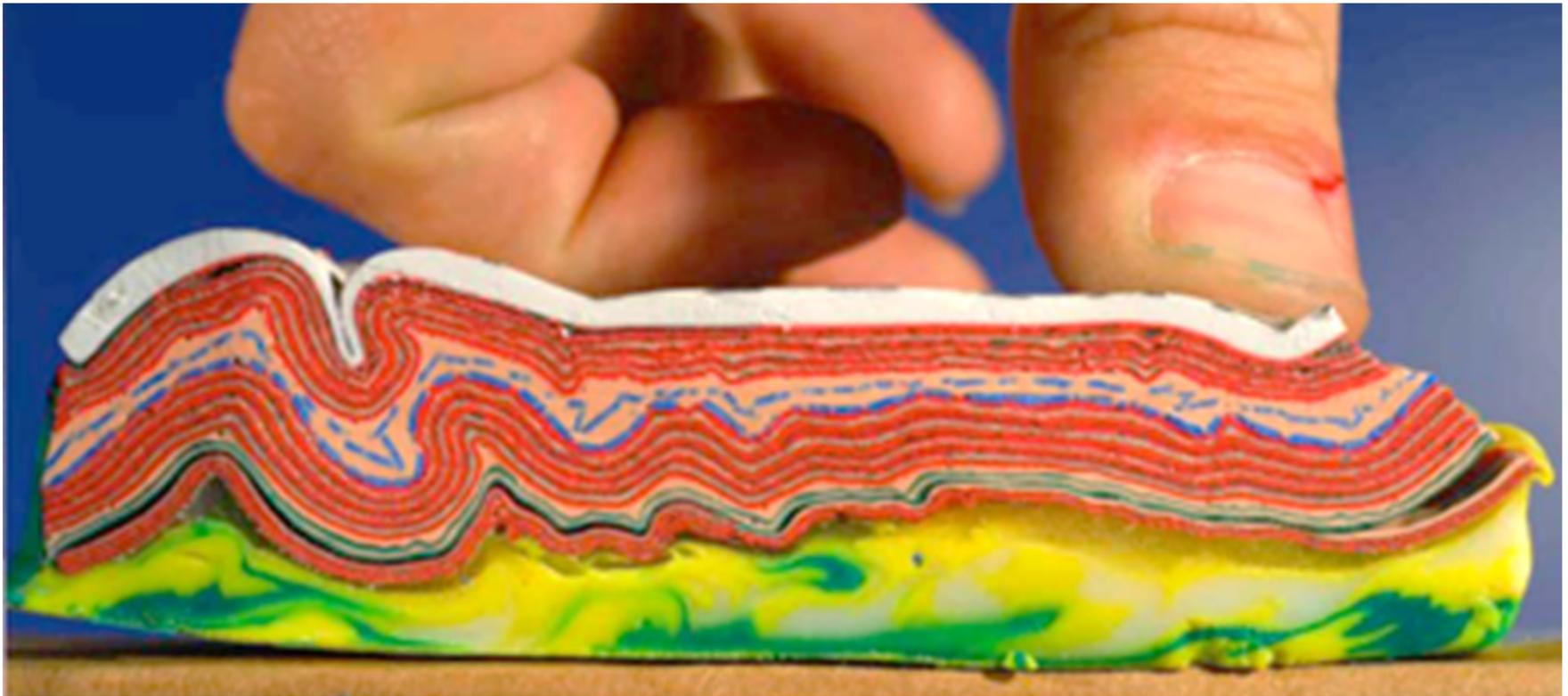

1980 : Queens, Expt. Tectonics

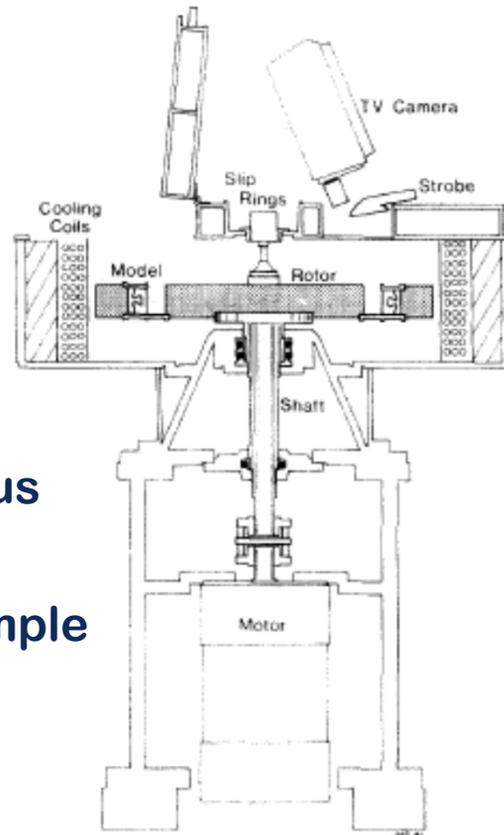
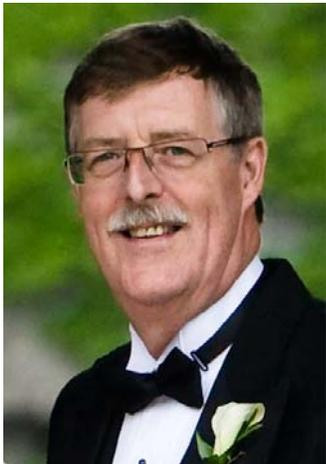

0.4m radius
20,000g
50mm sample

Dixon & Summers (1985)
J. Struct. Geology

'80-'90

'90-'00

'00-'10

'10- on



Crustal Deformations

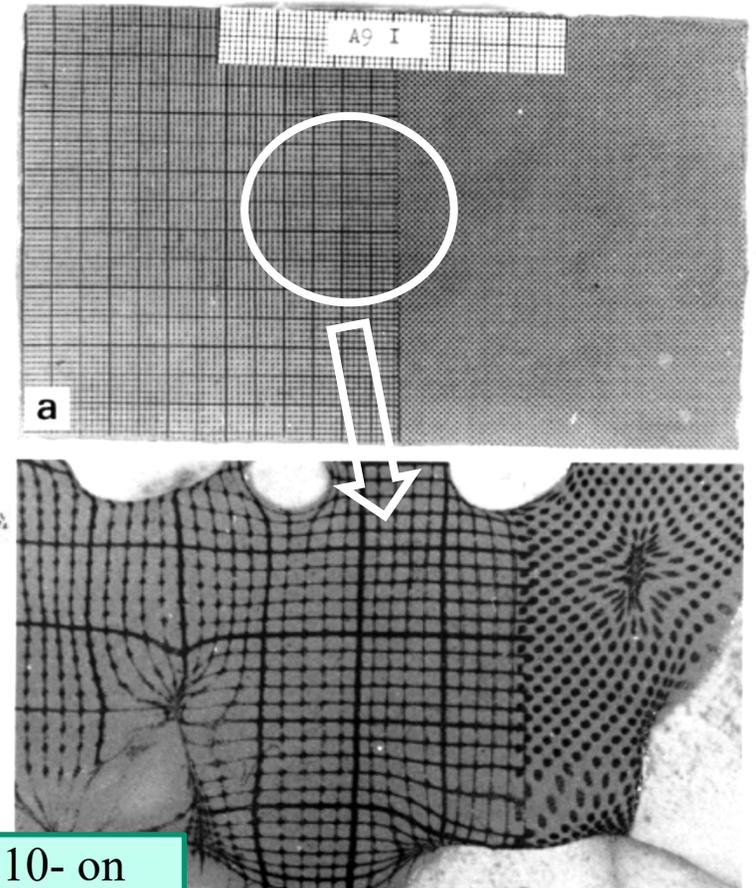
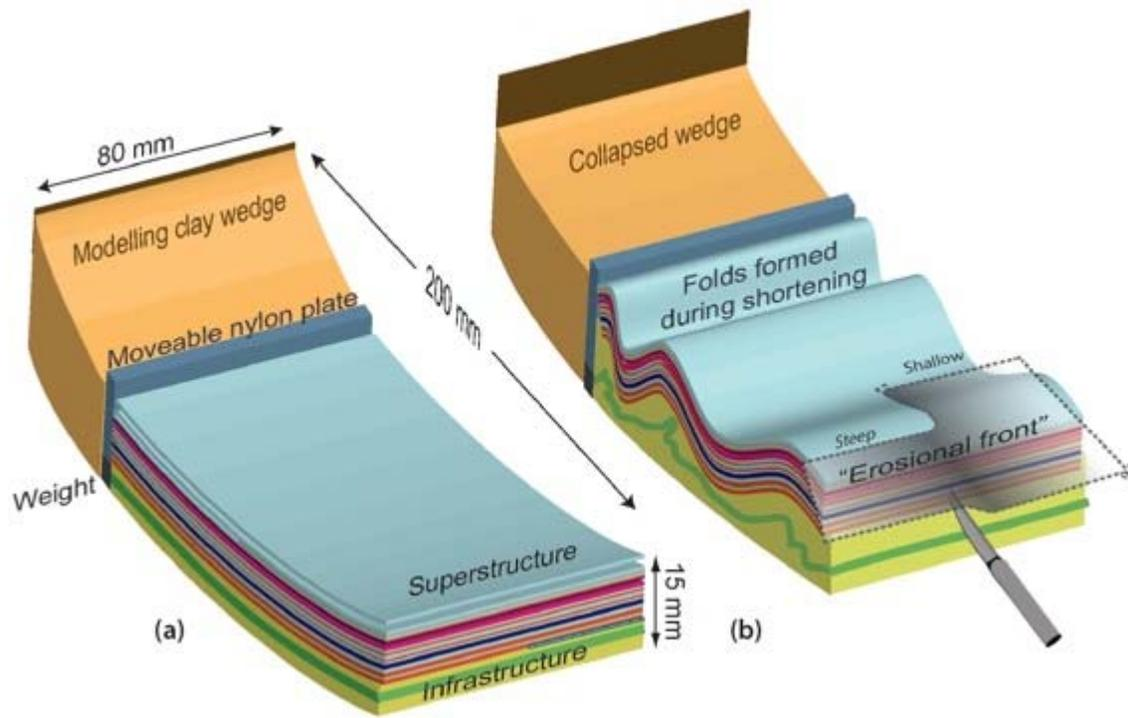

'80-'90 '90-'00 '00-'10 '10- on

1984 : Queens, Civil Eng.

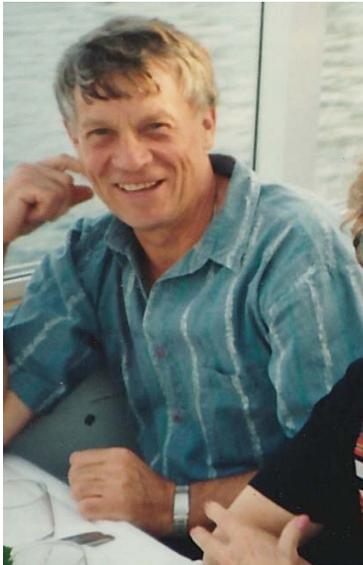

2.7m radius

300g

30g-ton

Mitchell (1986) CGJ



'80-'90

'90-'00

'00-'10

'10- on

Centrifuge Permeameter

Centrifuge model:
System : \int Element.dVol

Permeameter : Element behaviour

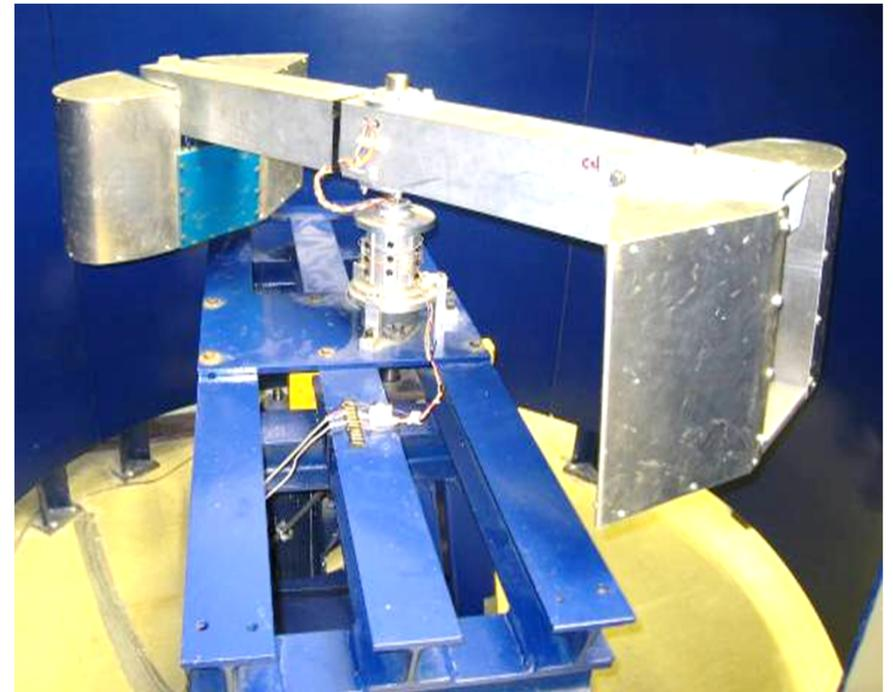

'80-'90

'90-'00

'00-'10

'10- on

1990 : U.N.B. Civil Eng.

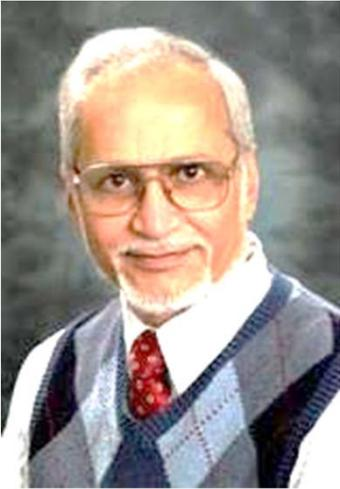

1.6m radius
200g
20g-ton

McAffee & Valsangkar (2008) CGJ



'80-'90

'90-'00

'00-'10

'10- on

Induced Trench Installation

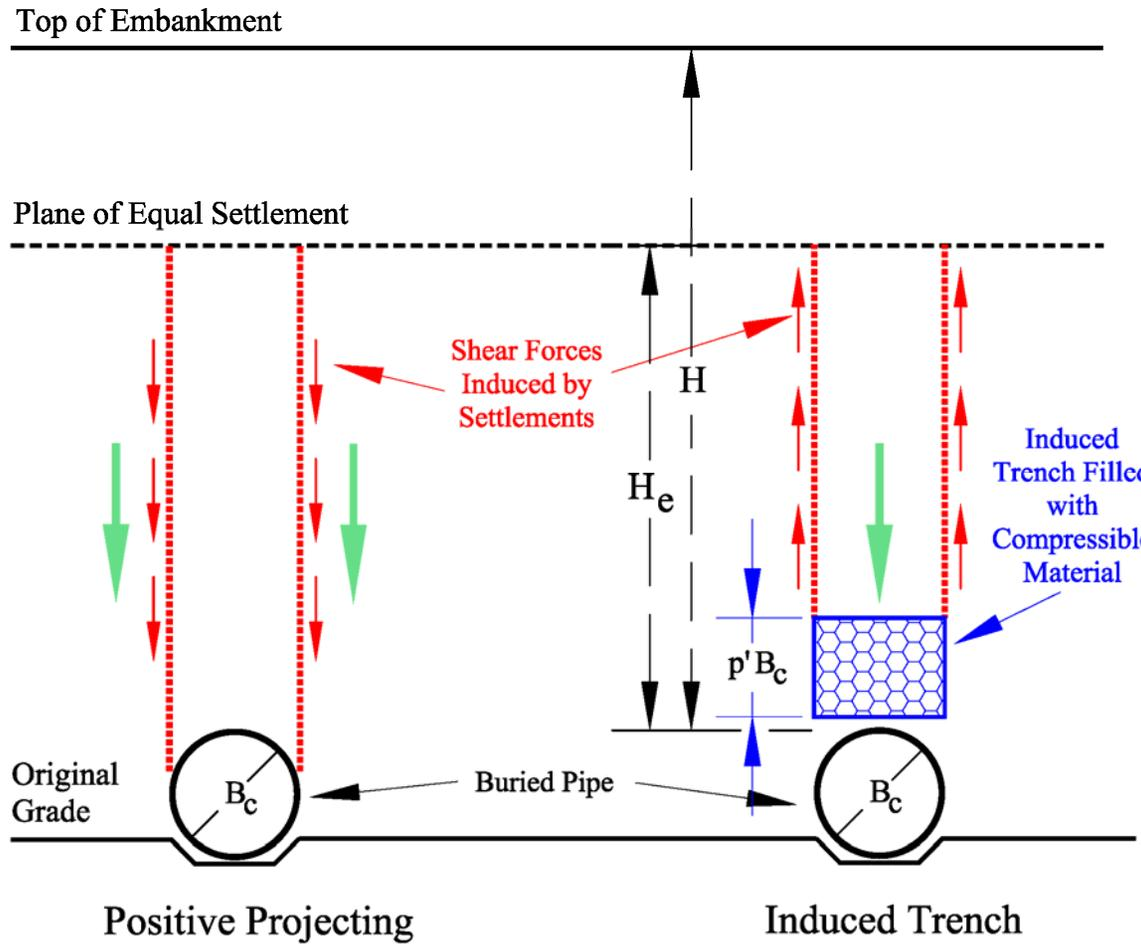

Minor Road Project

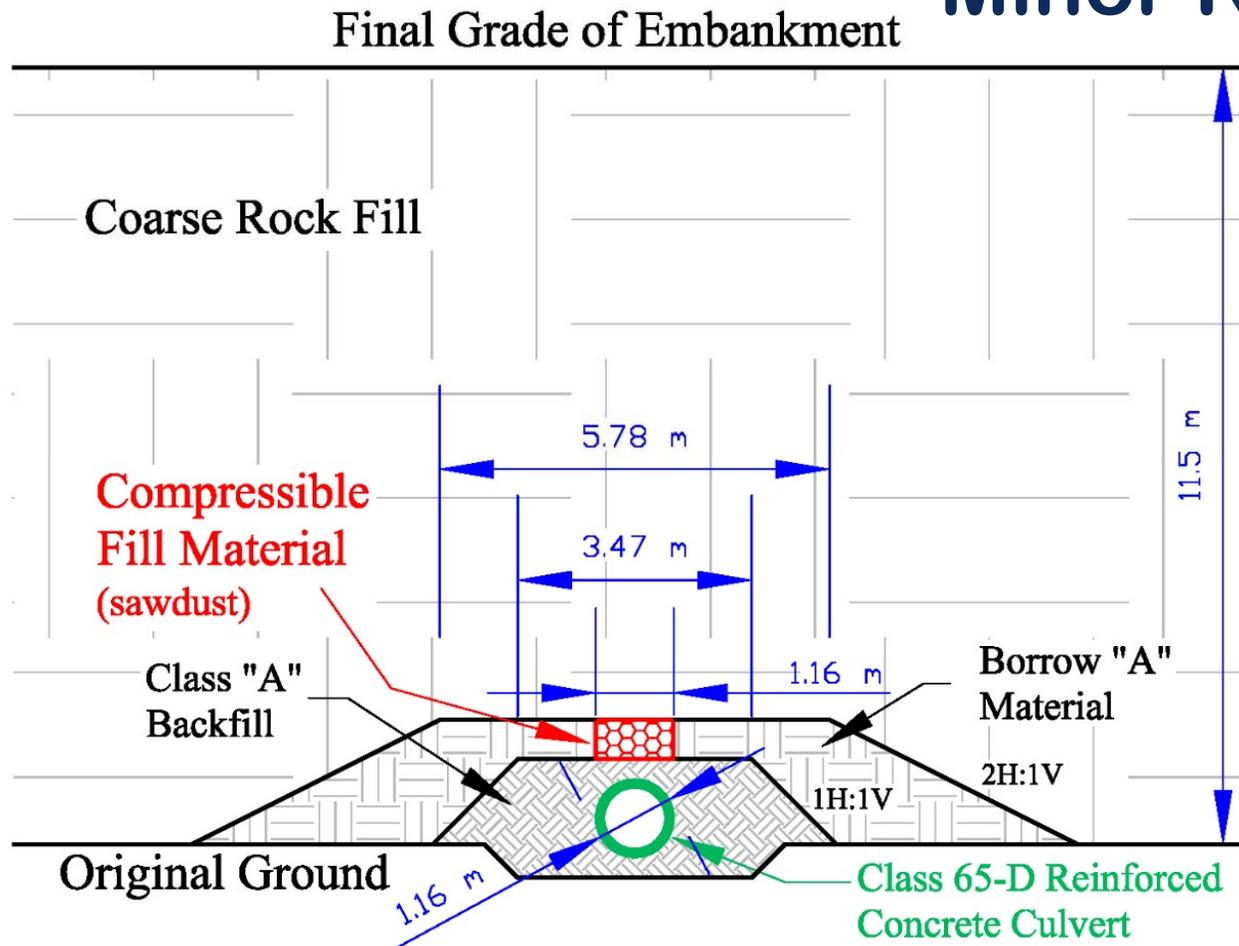

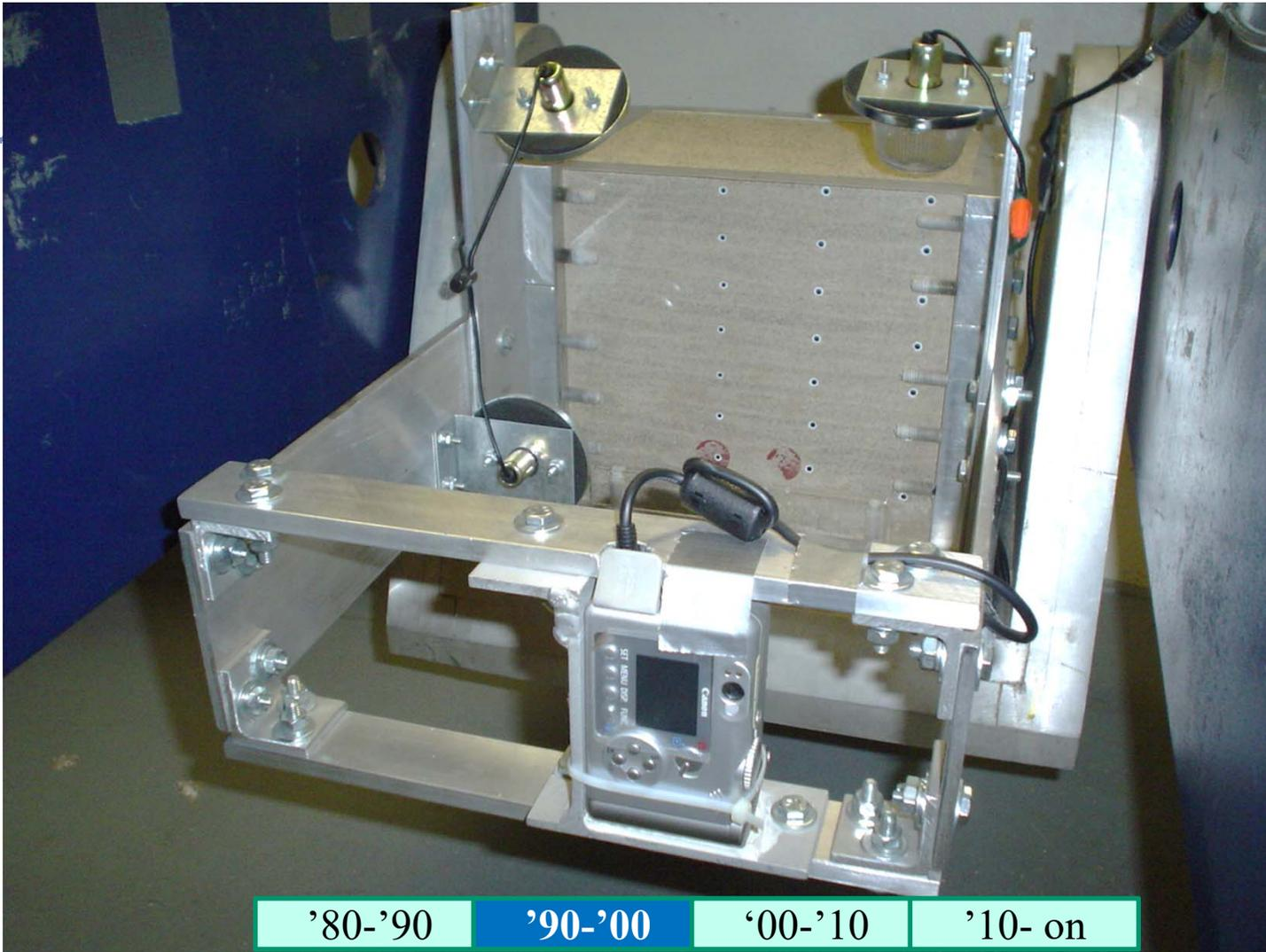

'80-'90

'90-'00

'00-'10

'10- on

Vertical Pressure Measured in Centrifuge

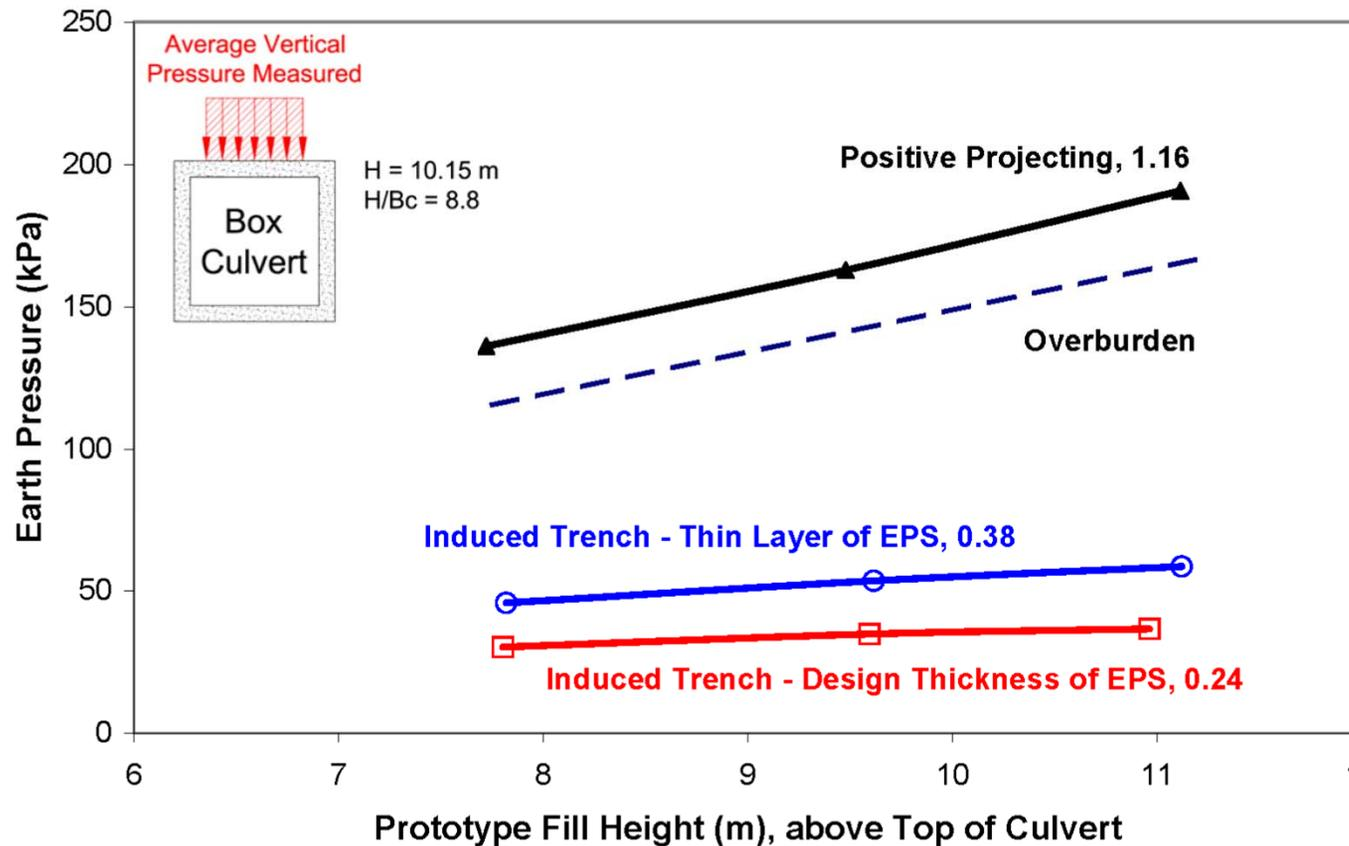

Pressure Measurement Comparison

	Field Measured Values	Centrifuge Model	FLAC Simulation
Induced Trench (centrifuge model parameters) [Box Culverts]		$\sigma_v = 36 \text{ kPa}$ ratio = 0.24 $\sigma_h = 72 \text{ kPa}$ ratio = 0.47	$\sigma_v = 30 \text{ kPa}$ ratio = 0.20 $\sigma_h = 83 \text{ kPa}$ ratio = 0.52
Induced Trench (field configuration) [Circular Culverts]	$\sigma_v = 49 - 78 \text{ kPa}$ ratio = 0.24 - 0.39 $\sigma_h = 93 - 110 \text{ kPa}$ ratio = 0.44 - 0.51		$\sigma_v = 79 \text{ kPa}$ ratio = 0.37 $\sigma_h = 118 \text{ kPa}$ ratio = 0.53
	'80-'90	'90-'00	'00-'10
			'10- on

1993 : C-CORE

5m radius
200g
200g-ton



'80-'90

'90-'00

'00-'10

'10- on



Canadian National Facility

- NSERC funded student access 1994 - 2014
 - 10 Universities & Other Research Institutes
- HMDC funded student access in 2015-2017
 - RDC funds enabled Drive Upgrade
- Recent student projects included
 - Urban frost heave
 - Rain induced landslides
 - Earthquakes on piles
 - Oblique pipe loads
 - Pile capacity deterioration
 - Gassy submarine slope stability



UNIVERSITY OF CALGARY



VÉRITÉ • DEVOIR • VAILLANCE

'80-'90

'90-'00

'00-'10

'10- on



Pipeline Frost Heave



Cross-Section of Cold Pipe in Unfrozen Soil

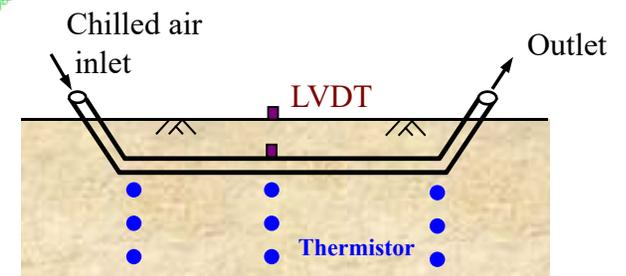
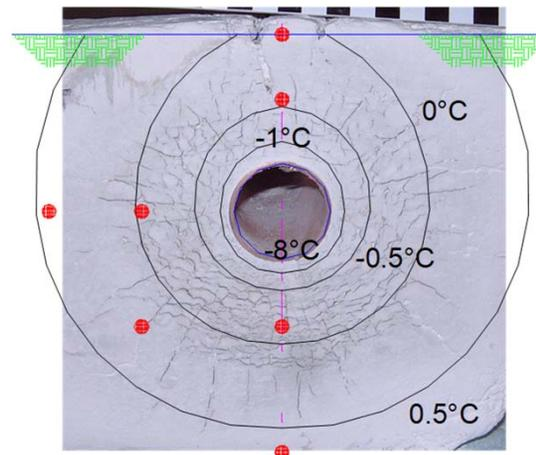
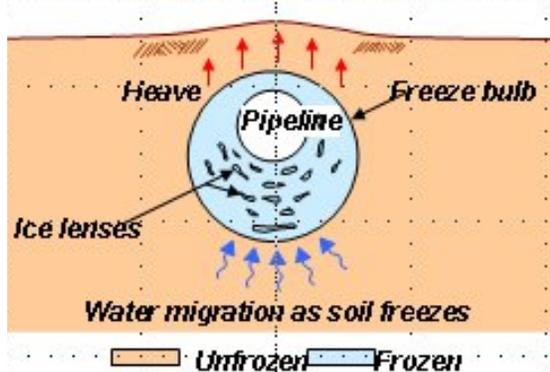

Calgary Frost Heave Pipeline Test Facility

4 Pipe Sections, 48" diameter
Control, Deep Burial,
Gravel Bed, Restrained

Carlson (1984) CGJ

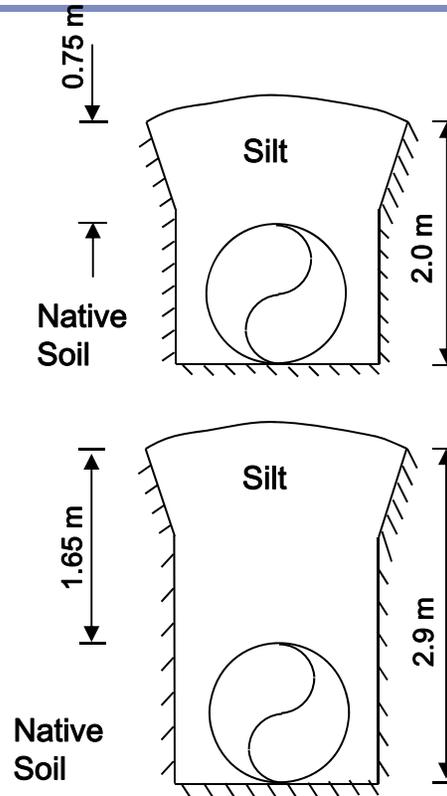

'80-'90	'90-'00	'00-'10	'10- on
---------	---------	---------	---------

Full-scale Comparison

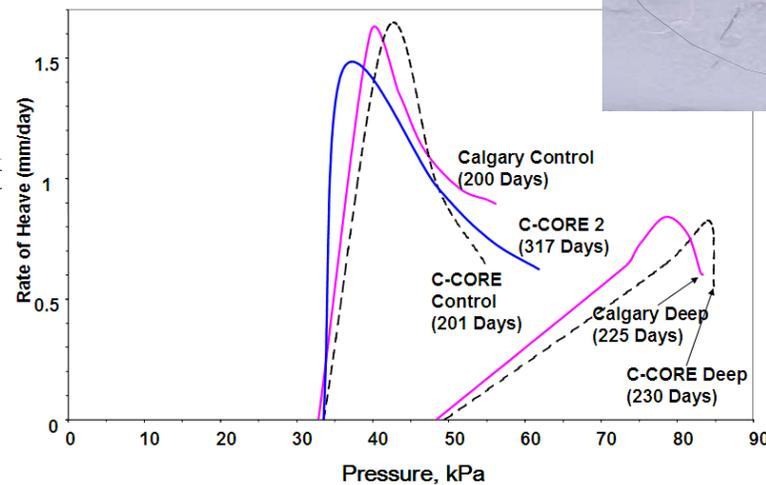
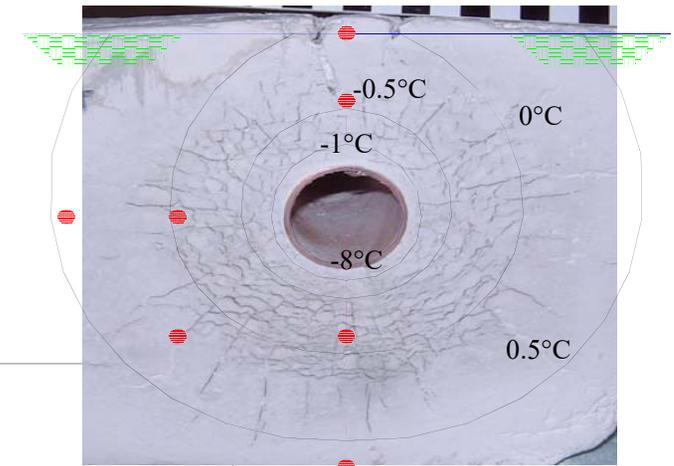
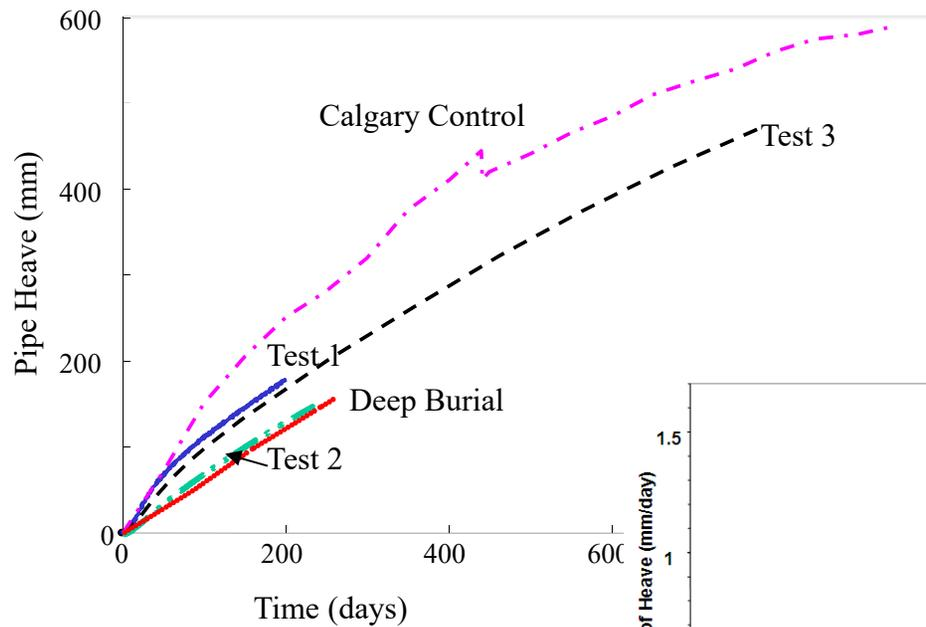

Clark et al (2001) CGC

McKenzie & Alaskan Gas Pipelines

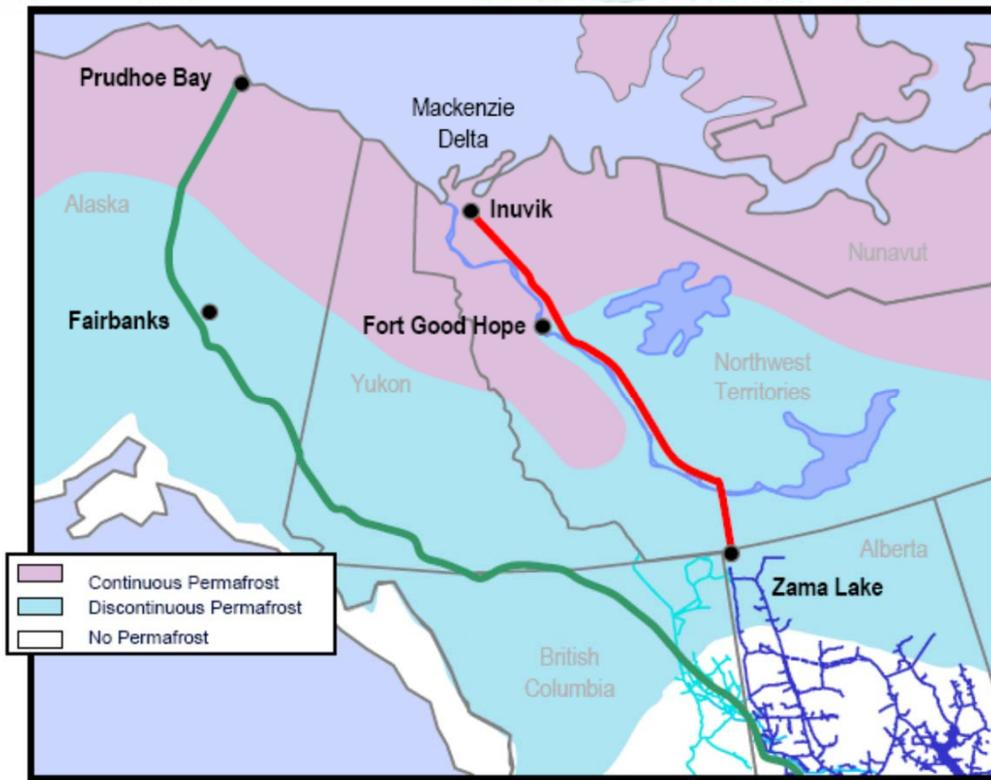

- Mitigation strategies
 - Drainage
 - Restraint
 - *Thermosyphons*
 - *Cyclic operation*

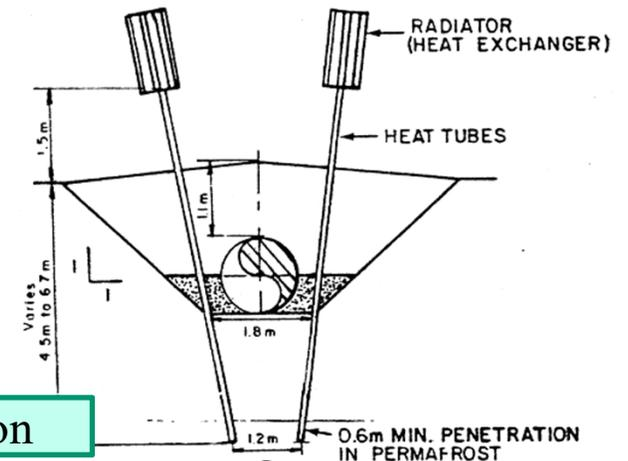

'80-'90 '90-'00 '00-'10 '10- on

CANLEX OVERVIEW

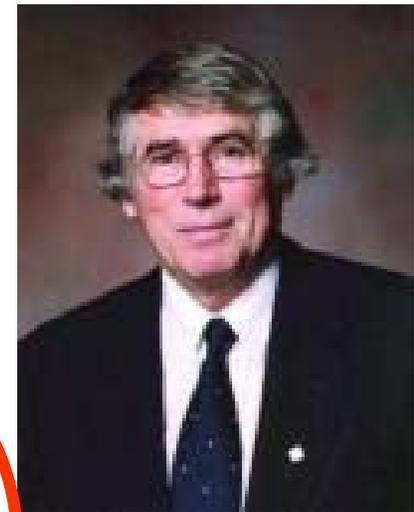
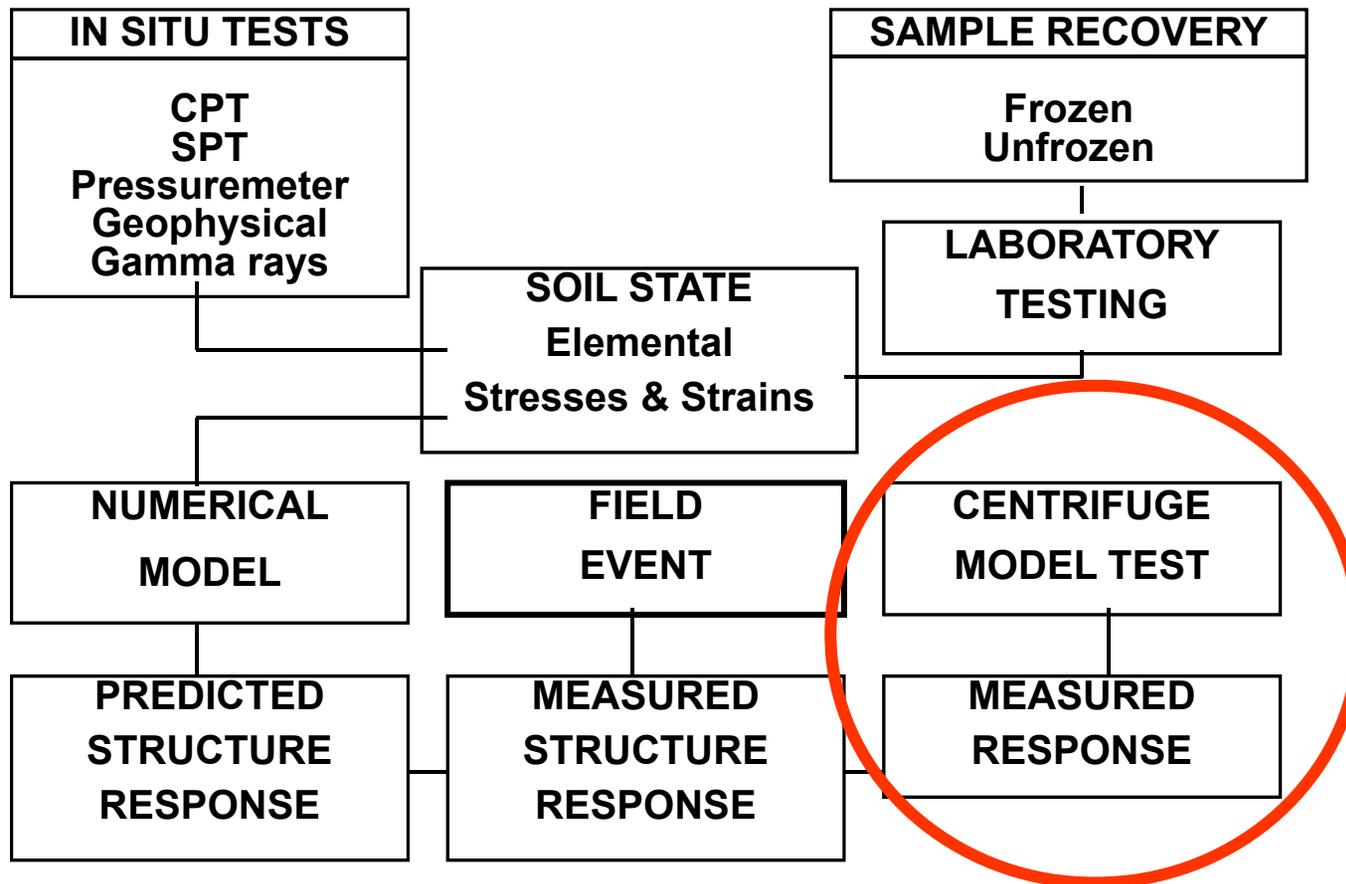

MODEL TEST

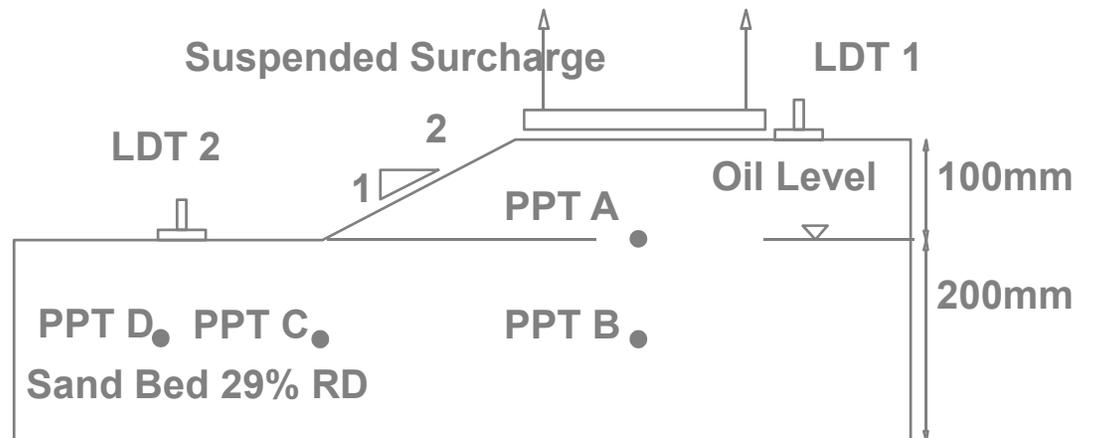

'80-'90

'90-'00

'00-'10

'10- on

COMPARISON

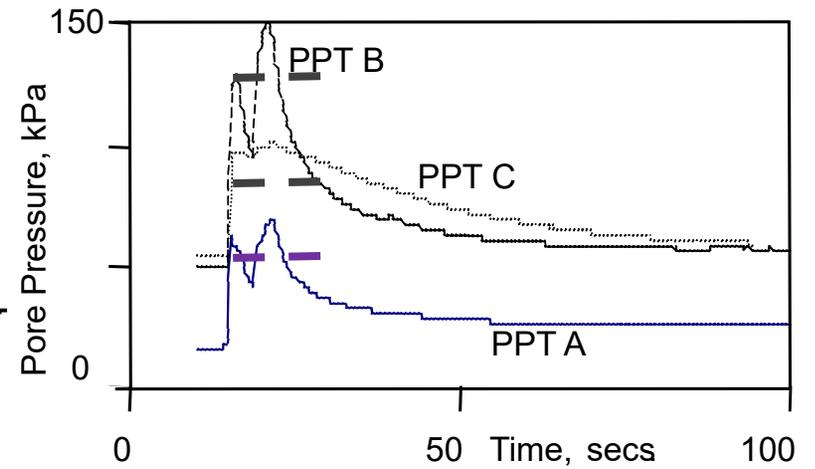
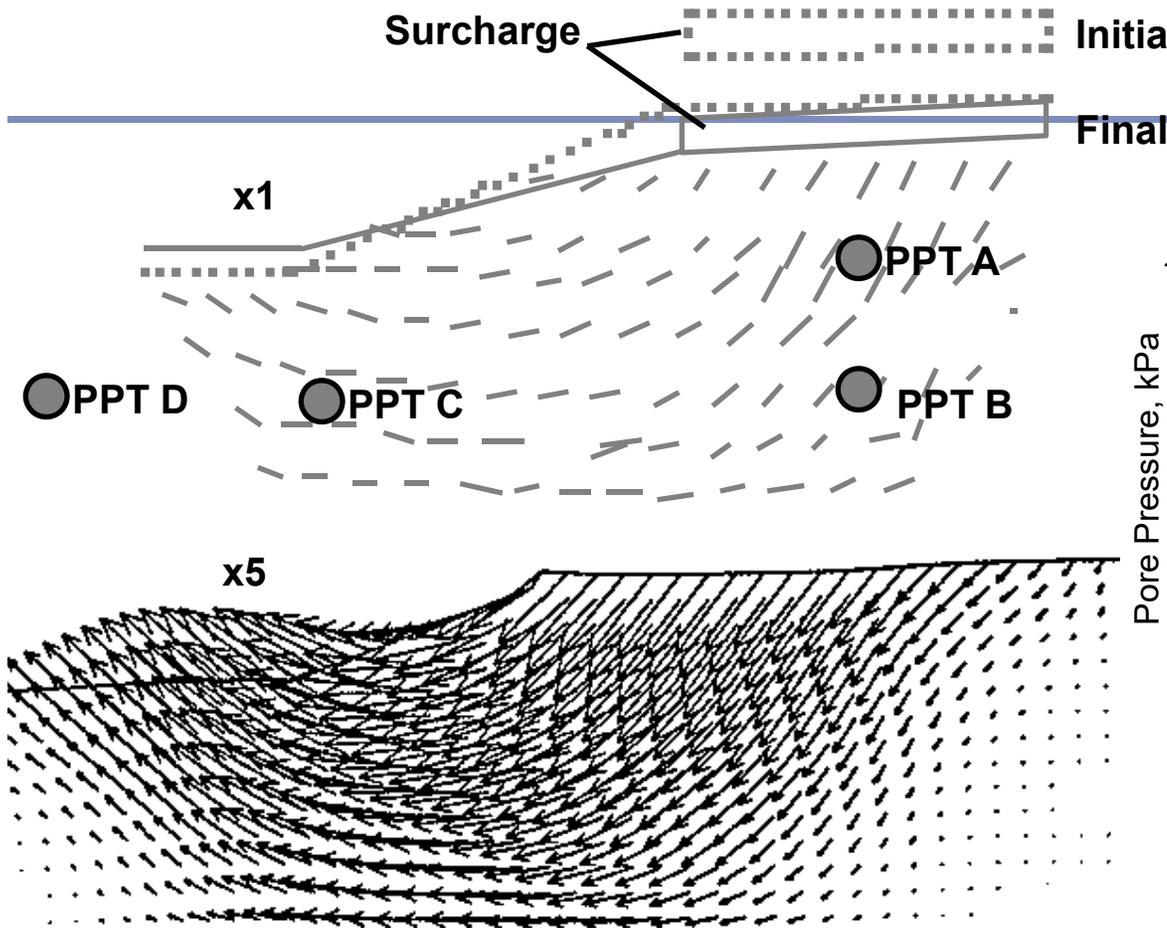

Puebla et al (1997) CGJ

Canadian Earthquake Hazard Mitigation

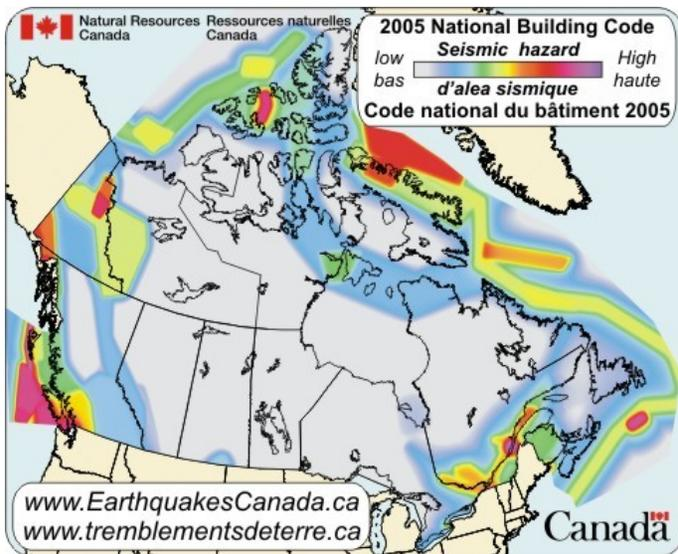

George Massey Tunnel

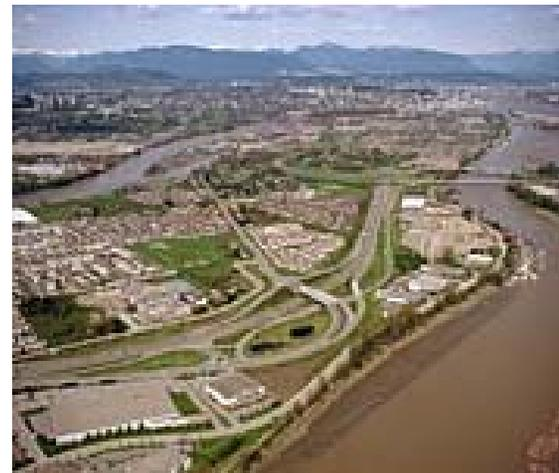

Liquefaction Remediation Initiative

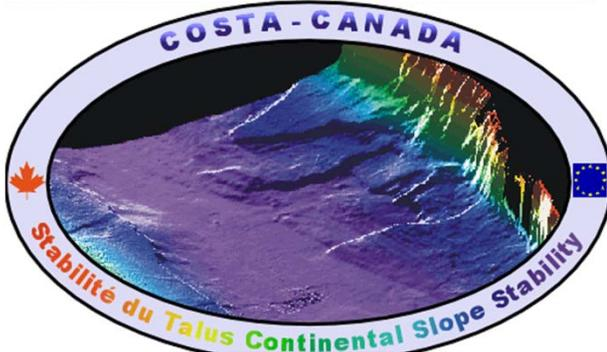

COSTA-B MODEL

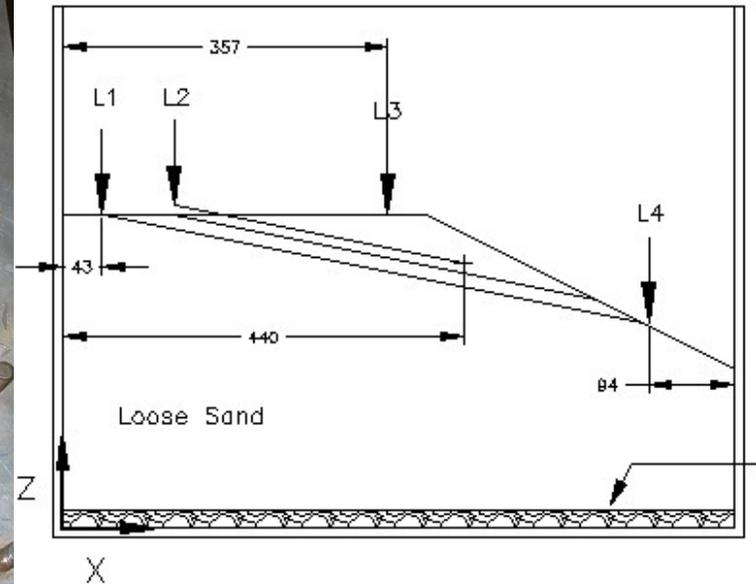
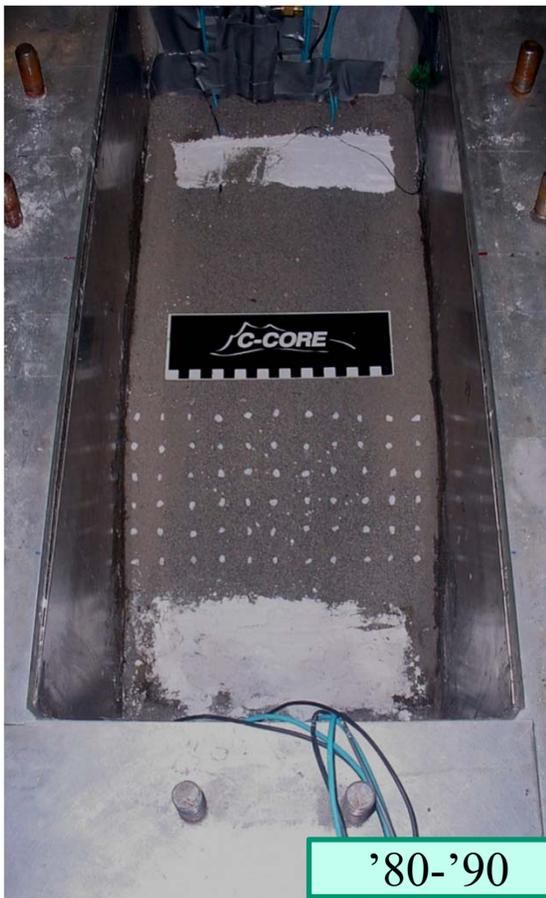

Model Scale 0 100 200 mm

COSTA-B Response

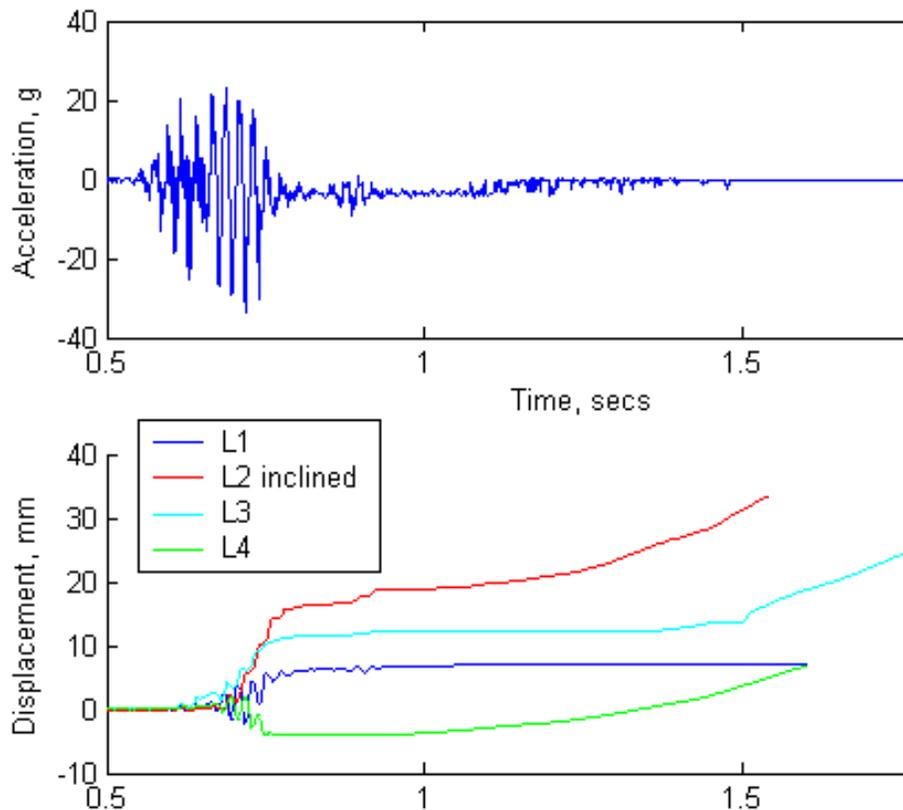

- Results included
 - Accelerations
 - Displacements
 - Pore pressures
 - Profiles
 - Photographs
- etc

Locat et al (2001)

'80-'90

'90-'00

'00-'10

'10- on

Liquefaction Remediation Initiative

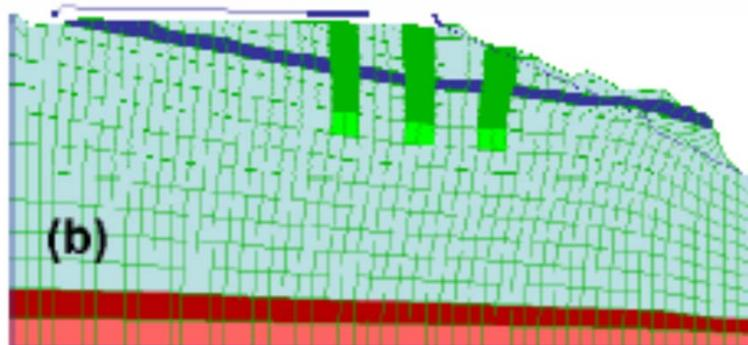
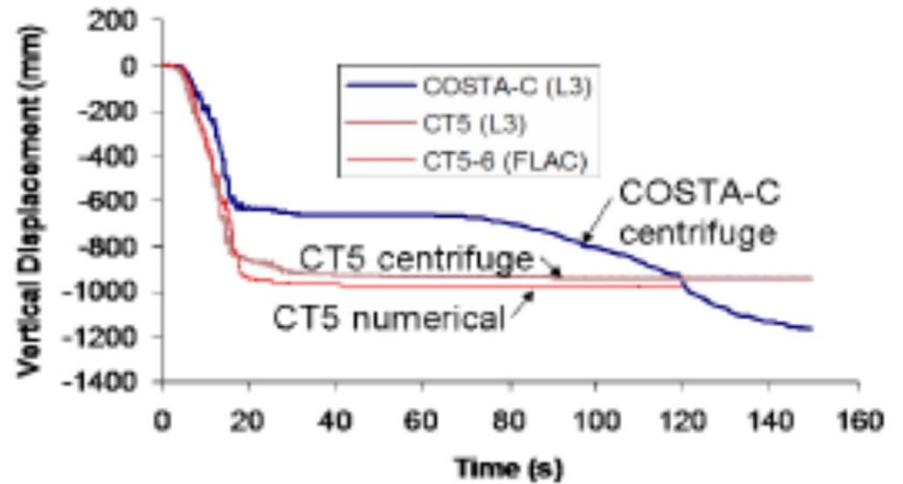
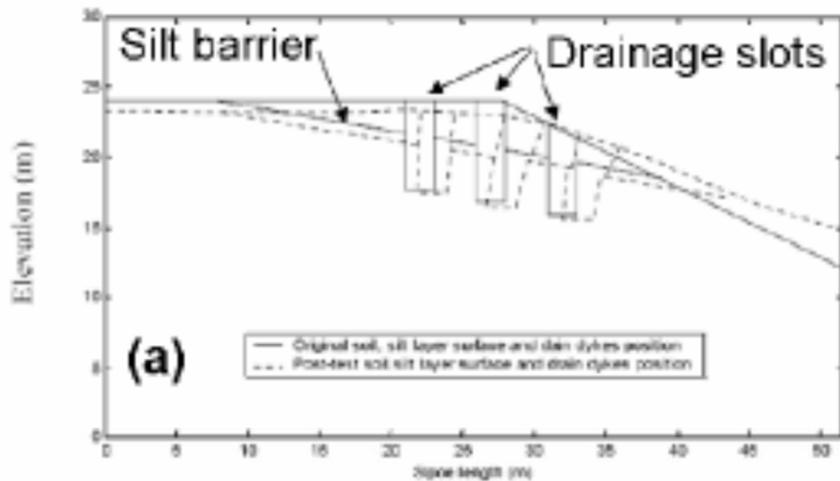

Naesgaard et al (2005)

Popescu et al (2005)

'80-'90	'90-'00	'00-'10	'10- on
---------	---------	---------	---------

George Massey Tunnel



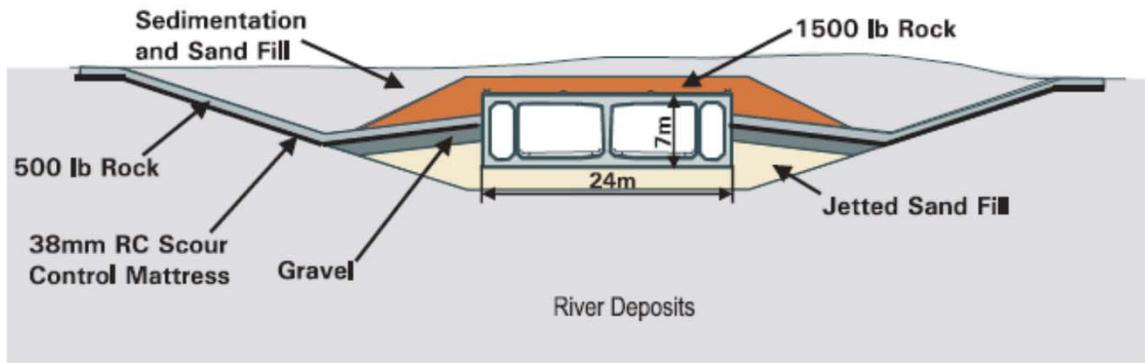

Yang et al (2004) CGJ

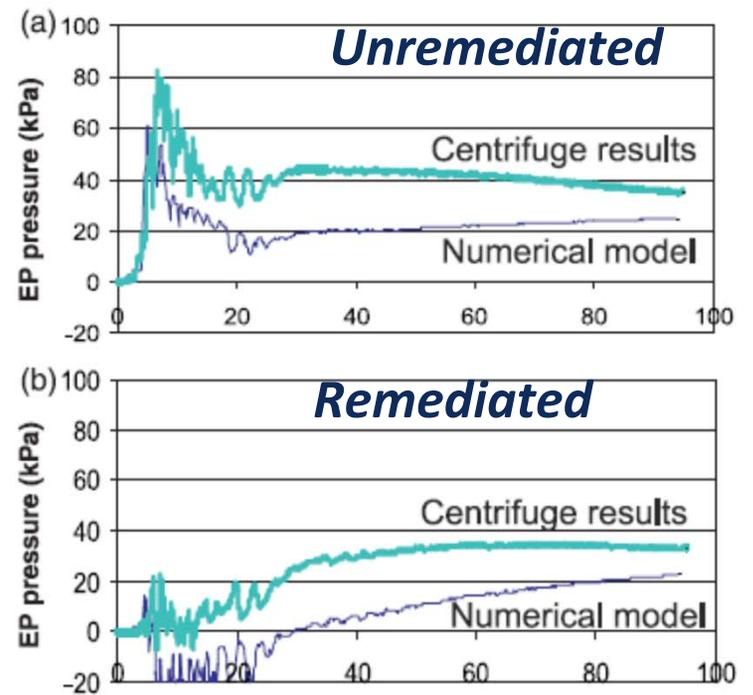
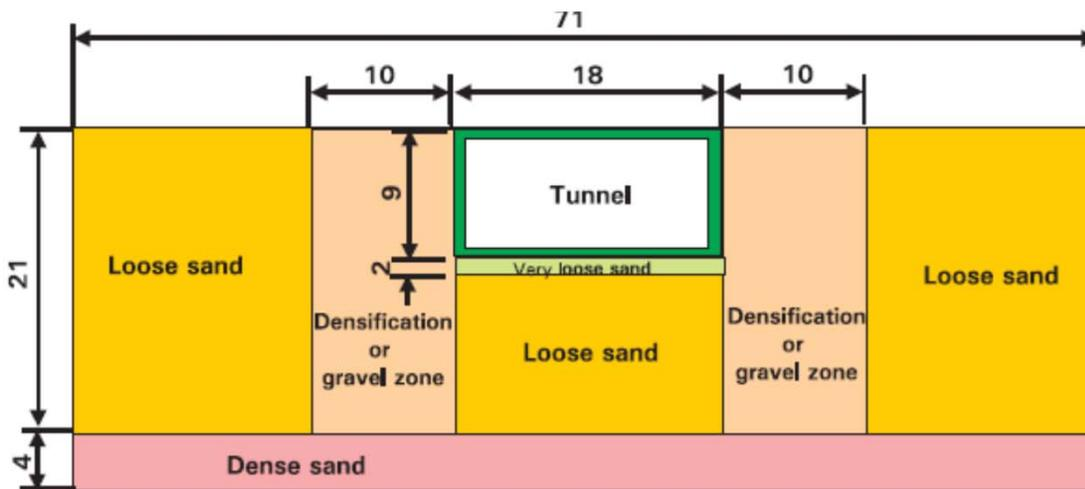

'80-'90 '90-'00 '00-'10 '10- on

Iceberg Gouging

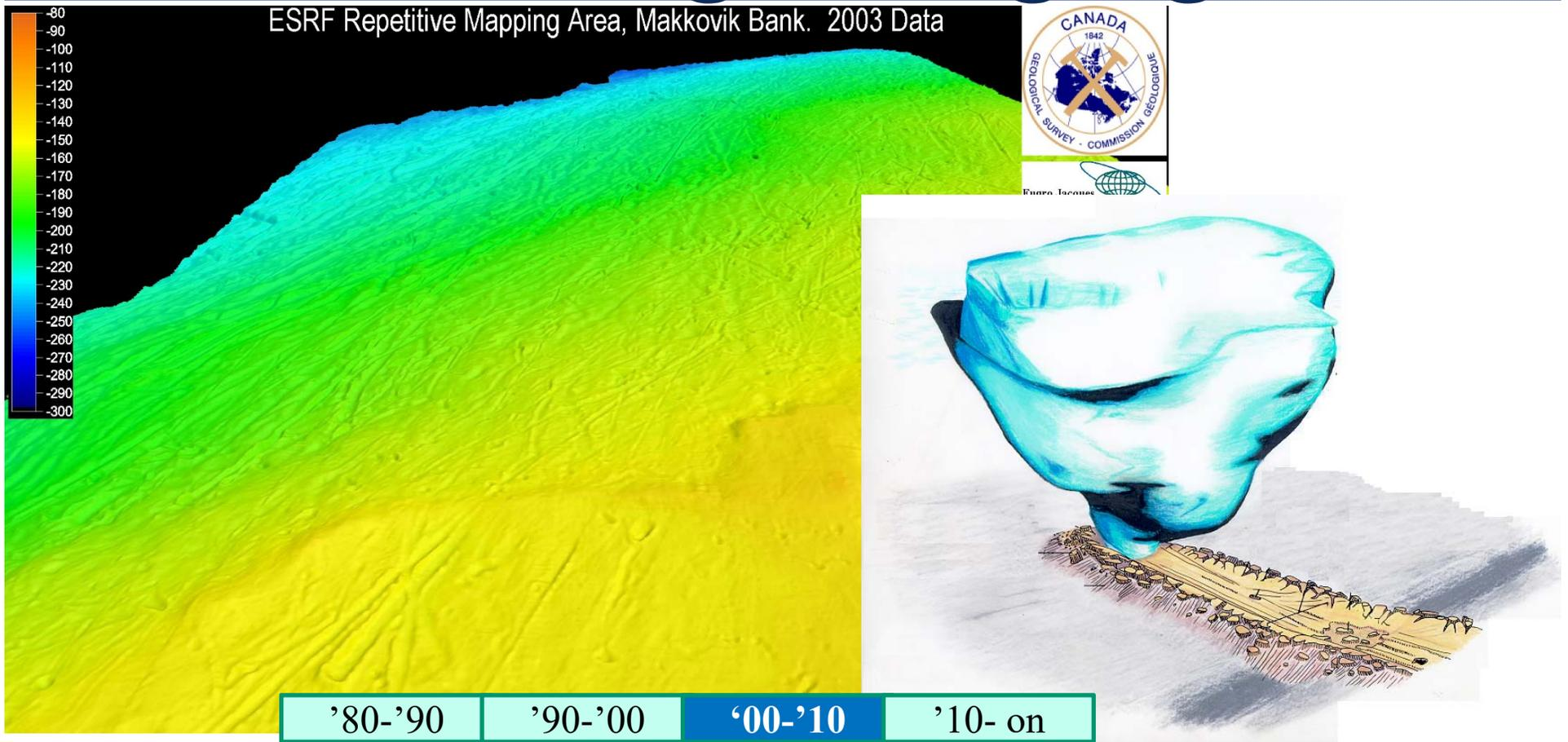

Subgouge Field Evidence

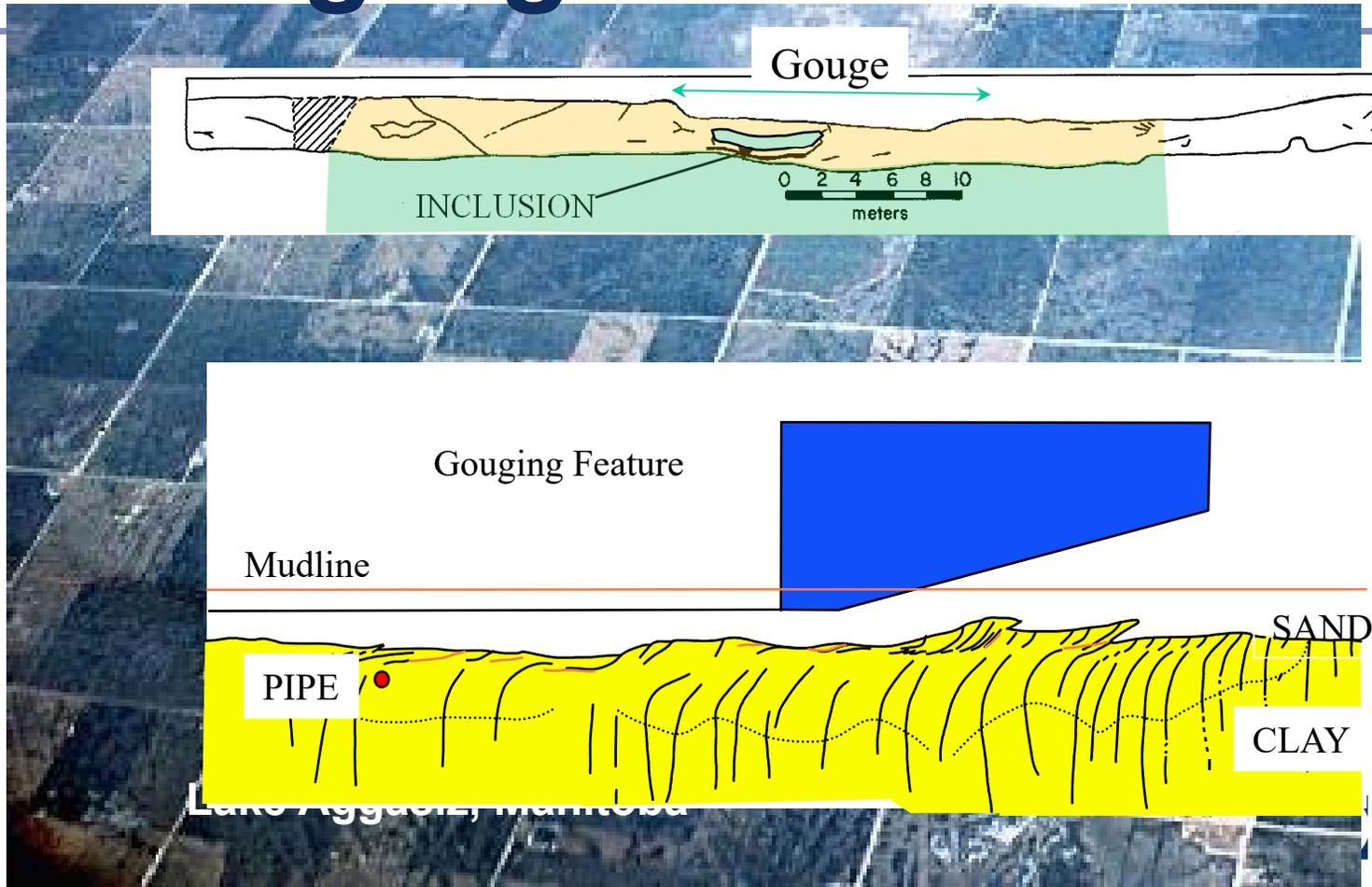

Phenomenological Validation

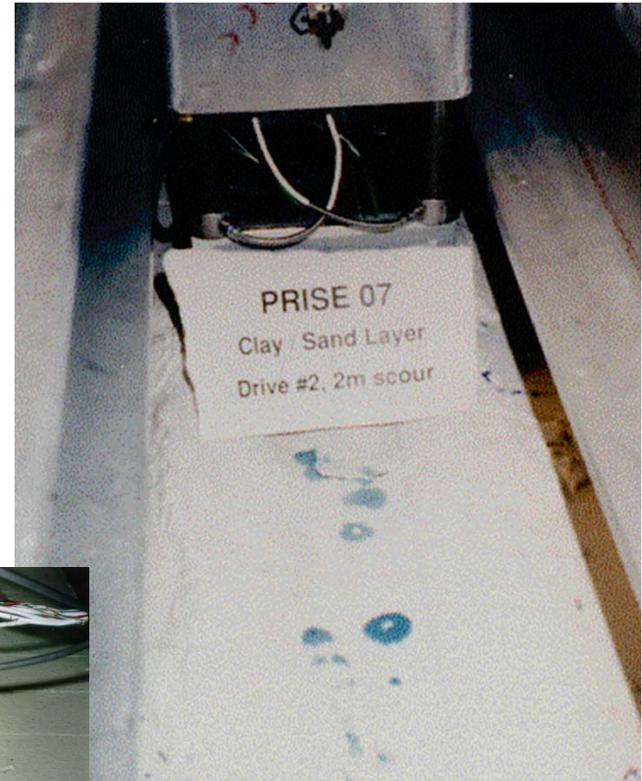

Sand boils in scour path?



Ice Keel/Seabed/Pipeline Interaction

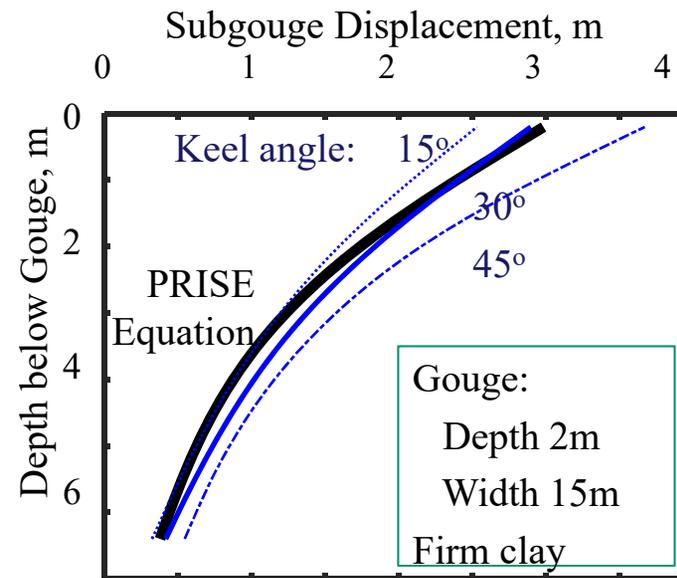
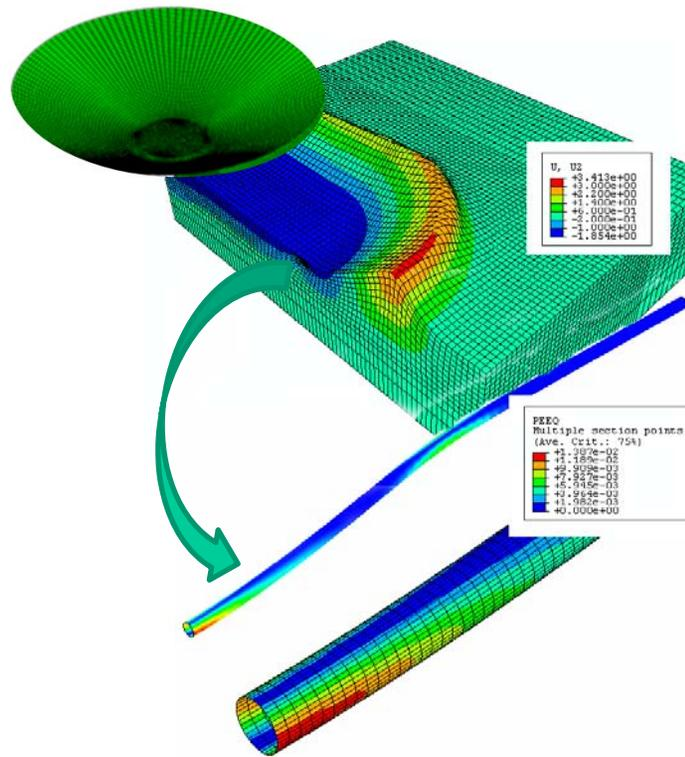

'80-'90 '90-'00 '00-'10 '10- on

2014 : U.o.A. Civil Eng.



2.0m radius

100g

50g-ton

'80-'90

'90-'00

'00-'10

'10- on

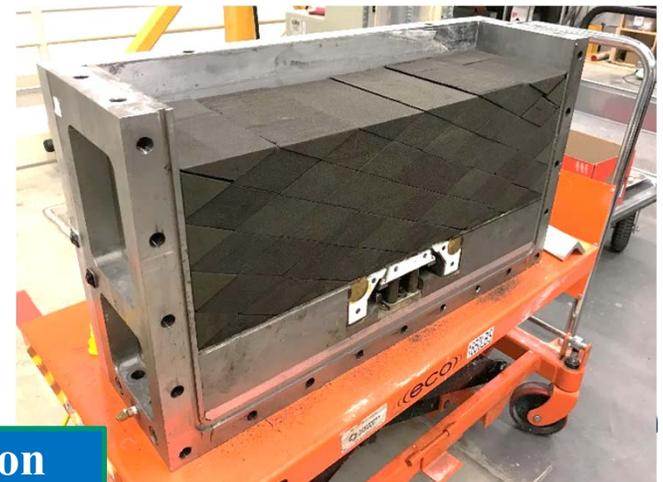
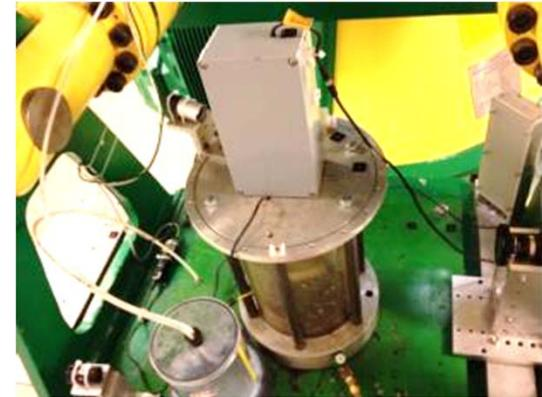

2016 : R.M.C.



0.7m radius

300g

506g-ton

'80-'90	'90-'00	'00-'10	'10- on
---------	---------	---------	---------

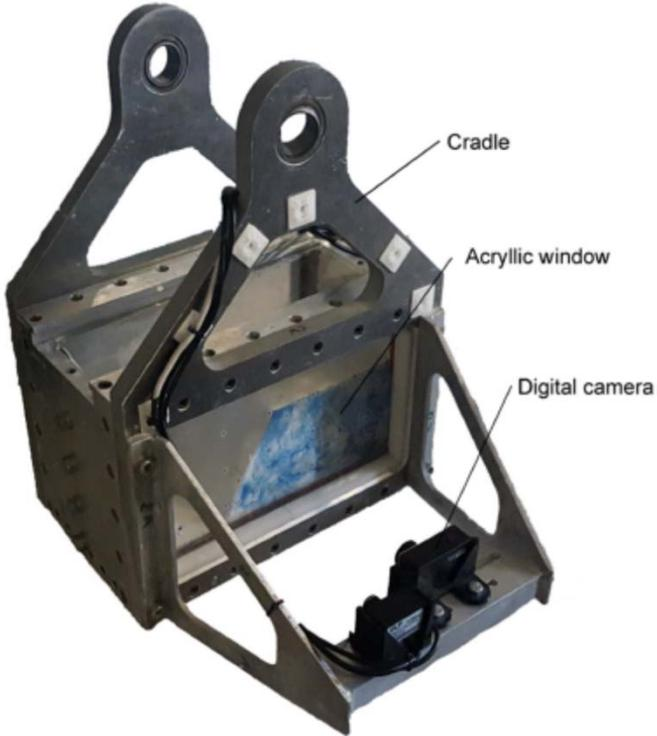

2019 on : UWO Drum Centrifuge



'80-'90	'90-'00	'00-'10	'10- on
---------	---------	---------	---------

Offshore NL

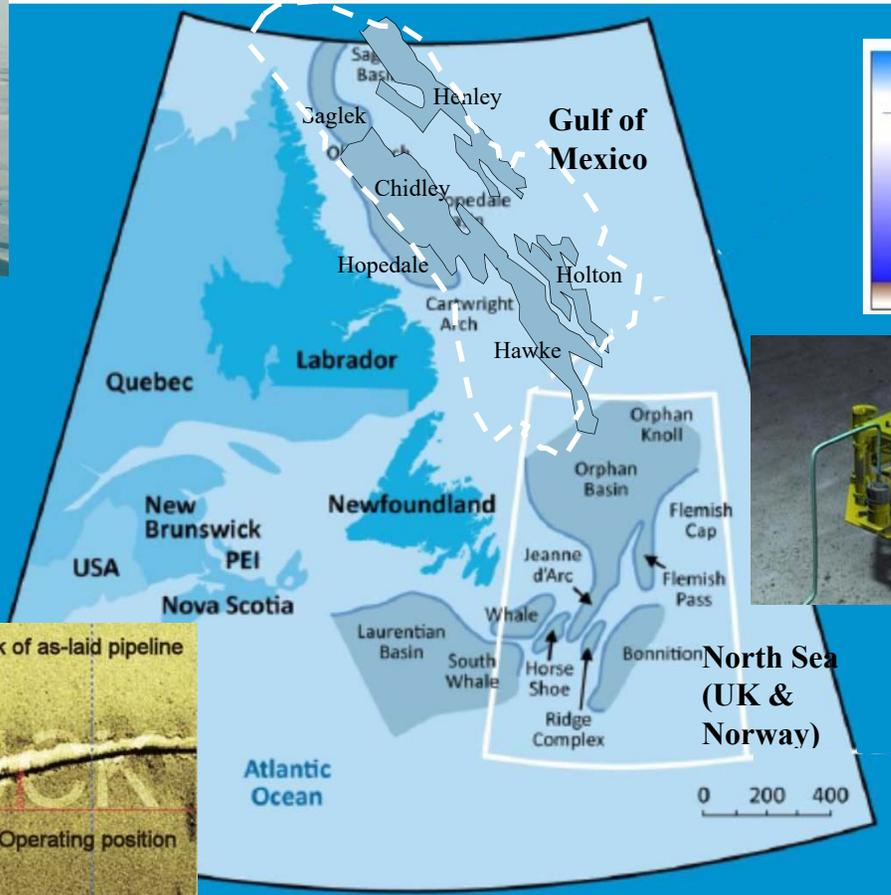
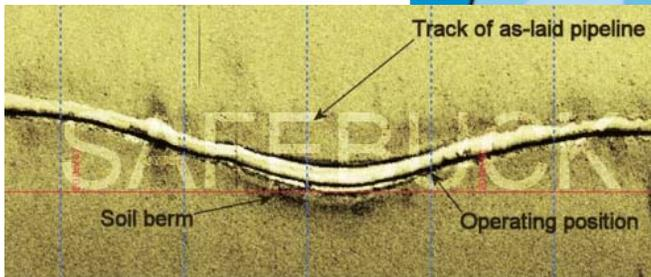

Riser Fatigue

